



VISIVE[®]
POWERED BY SMART TECHNOLOGY

HI-LITE[™] 30

CLASSIC

HI-LITE[™] 30

BORDER

HI-LITE[™] 30

CHROMA

Installation guide

Version 8. March 2022



IMPORTANT

Please ensure you read, understand **and** follow all the information and instructions in this guide.

Failure to install Hi-Lite 30™ as described in this document will void any product warranty.

If you have any queries regarding the content of this guide, please call **+44 (0) 1978 660181** or email **technical@visivegroup.com**



The installation

Hi-Lite™ 30 installations (see sample layout below) are made up from a number of standard sections (1), connected end to end. A Field Adjustable Section (2) is usually fitted at the end of each continuous run and is cut to size at the time of installation to exactly fit the structure.

Pre-terminated connection cables (4) connect the Hi-Lite™ 30 sections to the power supply (3), and are also used to bridge gaps around other signage or building features. When the electrical connection must continue after an adjustable section (for example around a corner), a 'Y' connection splitter (5) is used together with a connection cable. Blanking plugs (6) **must** be fitted to any unused connectors at the end of tube runs.

Although power supplies are IP rated for outdoor installation, they must be positioned so that water cannot pool around them or collect on the units themselves. If they must be mounted in an exposed location, place them inside a suitable transformer box or electrical enclosure.

Sample installation layout

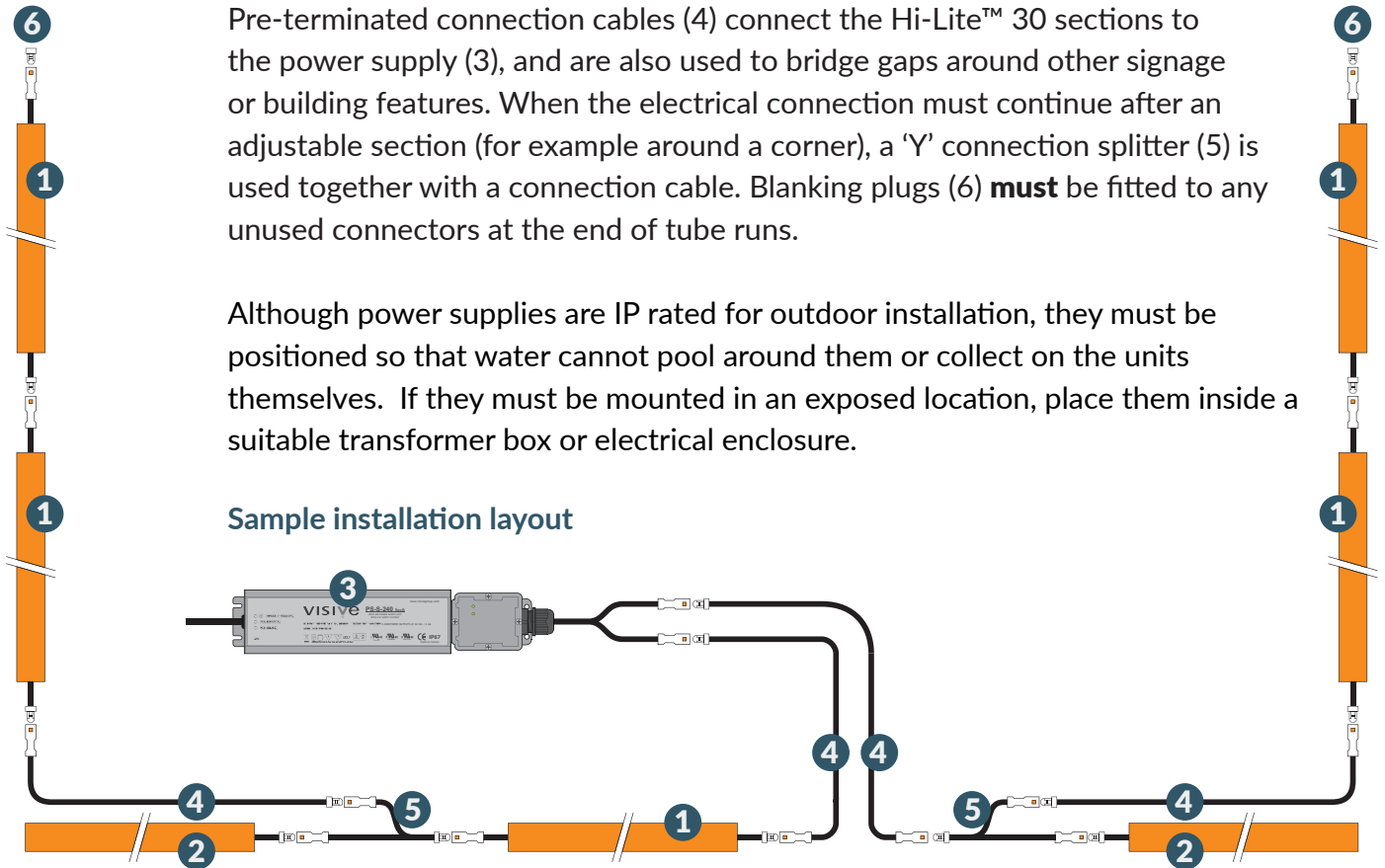

Installation key

1. Standard Hi-Lite™ 30 sections available in 2.4m (7'10½") lengths.
2. Field Adjustable Sections. Available in 2.4m (7'10½") and 1.2m (3'11¼") lengths.
3. 46V IP67 Power Supply Unit with CSC safety system. Available in 240W, 96W, 40W and 20W versions.
Order code(s):
PS-S-240
PS-S-96
PS-S-40
PS-S-20
4. Pre-terminated connection cables. Available in 1m (3'3½"), 3m (9'11"), 5m (16'5") and 10m (32'9¼") lengths.
Order code(s):
JC2-S-1
JC2-S-3
JC2-S-5
JC2-S-10
5. 'Y' connection splitter.
Order code(s): YC2-S-FMM
6. Connector blanking terminator (supplied with power supplies).
Order code(s): HL-BLANK

Visive Group Limited

Ash Road South, Wrexham Industrial Estate, Wrexham, LL13 9UG +44 (0) 1978 660181

www.visivegroup.com

The components

Hi-Lite™ 30 tubes are available in 2.4m (7'10½") standard lengths and 2.4m (7'10½") and 1.2m (3'11¼") Field Adjustable Sections. Most installations are made up from a number of standard sections, followed by a Field Adjustable Section cut to size during installation.

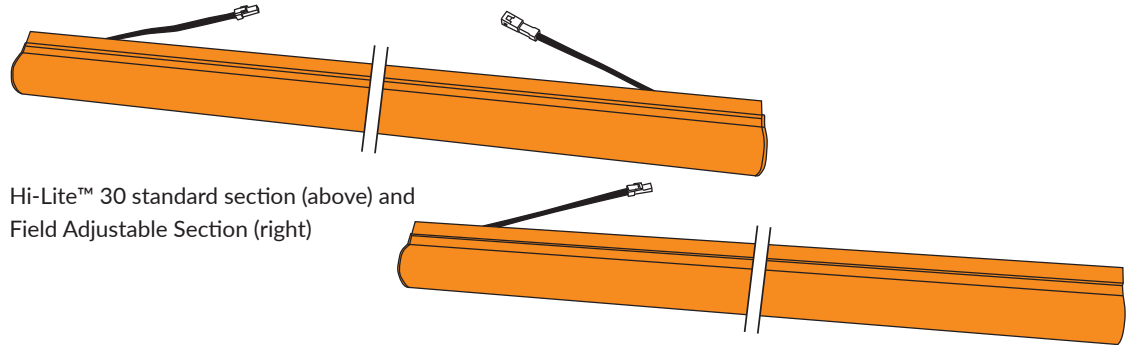

Hi-Lite™ 30 standard section (above) and Field Adjustable Section (right)

Standard sections feature a connector at each end and can be connected together in a simple daisy-chain configuration. Field Adjustable Sections have a connector at one end only, and once cut to length the remaining portion is discarded.

The Hi-Lite™ 30 system includes a range of IP-rated power supply units, as well as connection cables, 'Y' adapters, clips and connector blanking plugs.

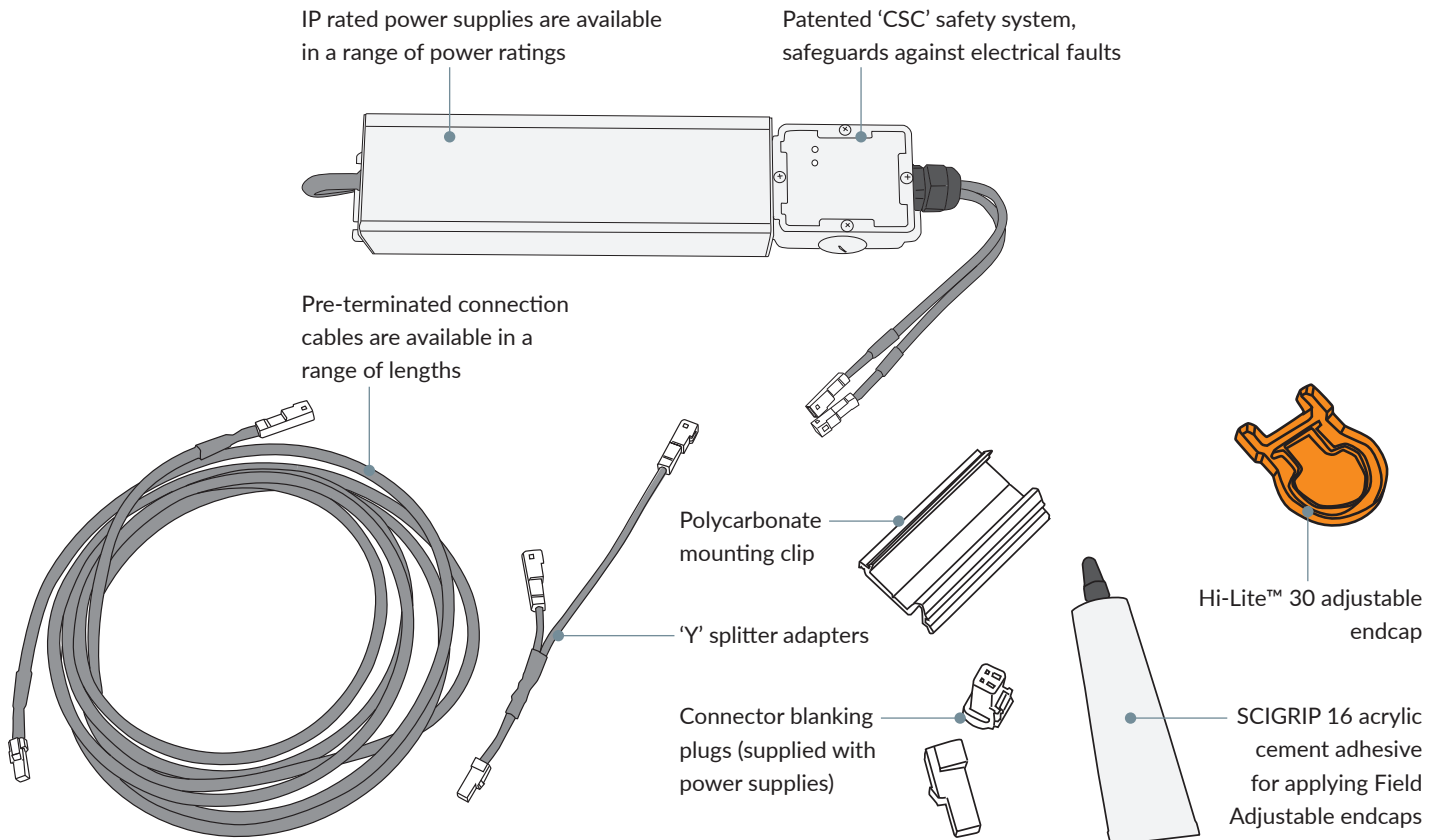

Visive Group Limited

Ash Road South, Wrexham Industrial Estate, Wrexham, LL13 9UG +44 (0) 1978 660181

www.visivegroup.com

The installation (continued)

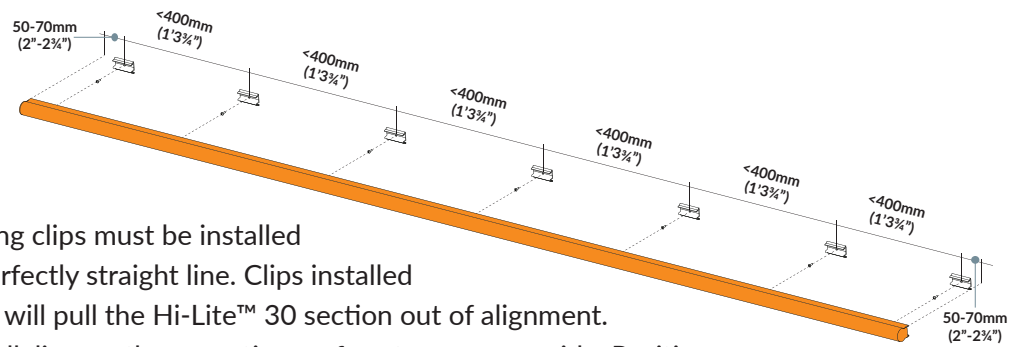

1. Mounting clips must be installed along a perfectly straight line. Clips installed off-centre will pull the Hi-Lite™ 30 section out of alignment. Snap a chalk line on the mounting surface to use as a guide. Position a clip 50-70mm (2"-2 $\frac{3}{4}$ "") from the end of each Hi-Lite™ 30 section and at least every 400mm (1'3 $\frac{3}{4}$ "") along each length.

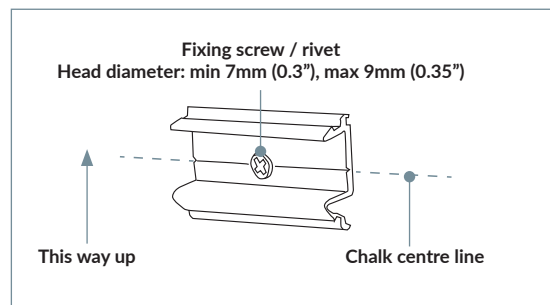

2. On horizontal installs, clips must be installed with the spring part of the clip to the bottom edge. The groove along the rear of the clip indicates the centre line of the Hi-Lite™ 30 tube once installed. Use fixings with head diameter between 7mm (0.3") and 9mm (0.35").

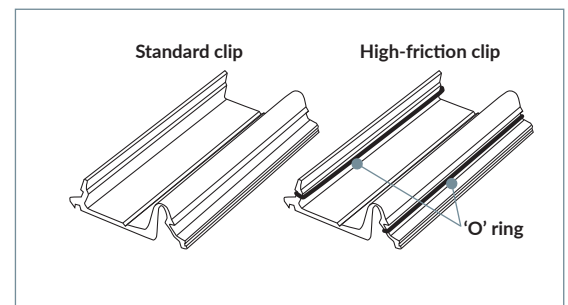

3. Two types of clip are supplied. A high-friction clip should be used in the centre of the section. This clip features a rubber 'O' ring to increase the grip on the tube, thereby locking it in position. Only one high-friction clip must be used per section.

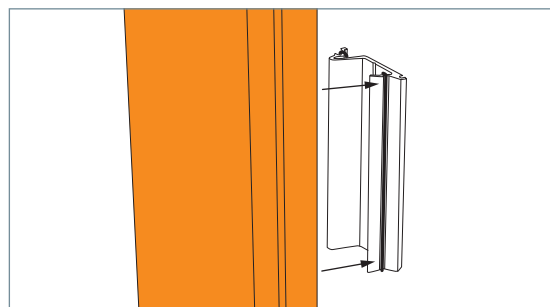

4. On vertical installations, the high-friction clip is particularly important to prevent Hi-Lite™ 30 sections from slipping down over time.

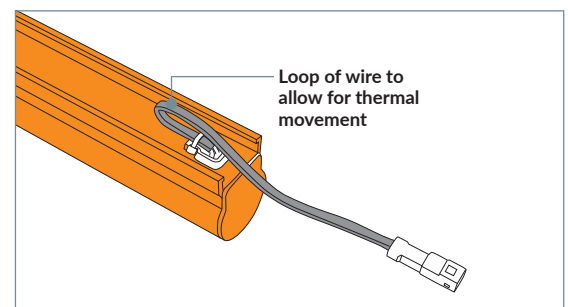

5. If a standard section is to connect to further sections loop the output connection as shown before fitting the tube into position. Leave a loop of cable to allow for movement due to thermal expansion and contraction.

The installation (continued)

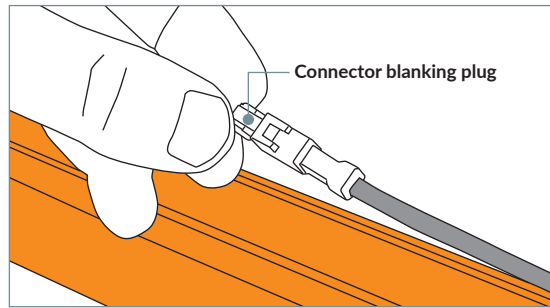

6. If the section is the end of the electrical circuit, a connector blanking plug (supplied with power supply) **MUST** be fitted to the unused connector. Failure to fit the blanking plug may allow water to penetrate the system, which will cause the CSC safety device to remove power.

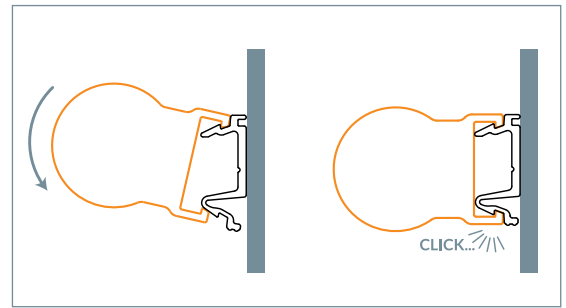

7. Hook the Hi-Lite™ 30 tube section into the top of the clip as shown, then rotate down until the bottom edge clips into place. Ensure the tube is properly located in the clip and that no wires are trapped. A 'click' should be heard when the tube is located correctly.

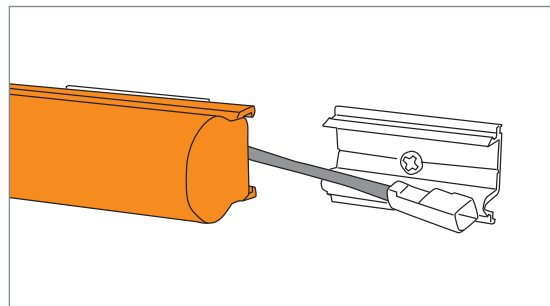

8. Hi-Lite™ 30 tube section clipped in place, with the cable positioned ready to connect to the next section.

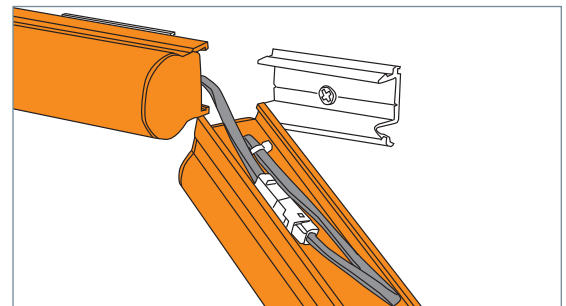

9. Connect the next tube, looping the cable around in the rear channel. Once again leave a loop of cable to allow for thermal movement.

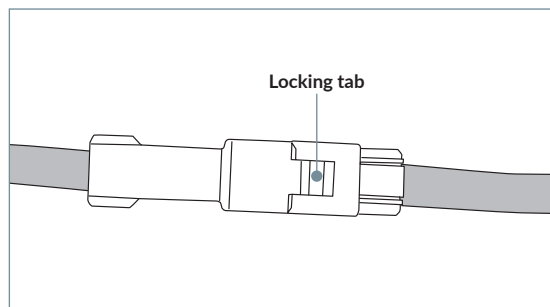

10. In order to maintain weather sealing connections must be properly made. When connected correctly the two halves will be locked together and will not pull apart without first releasing the locking tab.

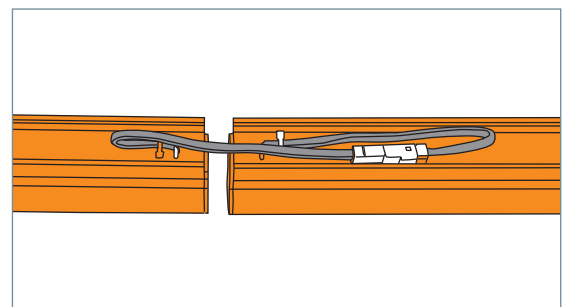

11. Viewed from the rear of the tube, the connection is hidden within the rear channel. When fixing the second section, check carefully that the cables are not trapped and sit freely between the tube and the clips.

The installation (continued)

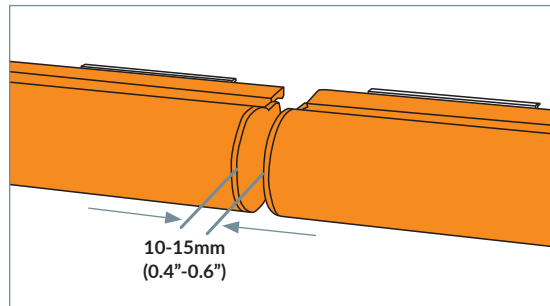

12. DO NOT butt sections up together. Doing so will cause the sections to bend in warm weather. Leave 10-15mm (0.4"-0.6") gap for thermal expansion. In very cold weather a larger gap may be required. If the Hi-Lite™ 30 sections are installed at a 2.4m (7'10½") pitch, the required expansion gaps will automatically be present.

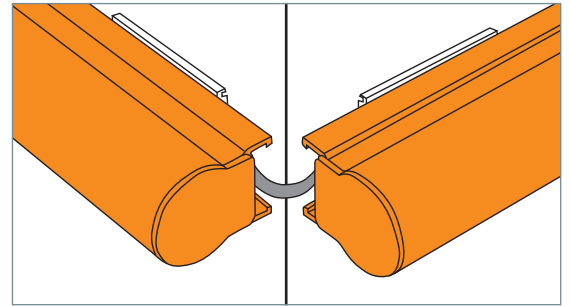

13. Hi-Lite™ 30 tube sections can be run up to the edge of external corners. It is not recommended to overlap the sections.

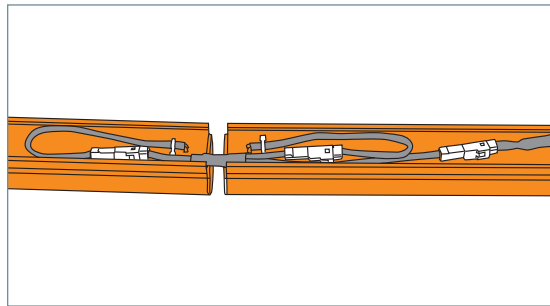

14. 'Y' splitter adapters can be used with Field Adjustable Sections to enable the electrical circuit to continue (around corners for example). The 'Y' adapter can be hidden behind the tube in the same way as a standard connection.

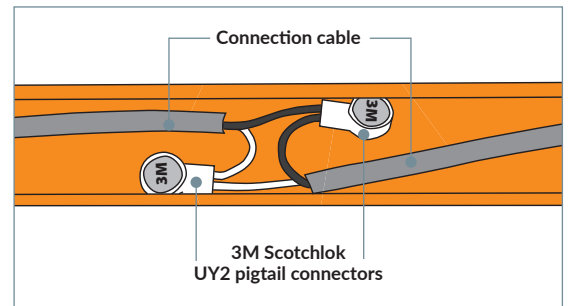

15. If a connection cable needs to be shortened, this can be done using two 3M Scotchlok gel-filled pigtail connectors, such as type UY2. The completed connection can be hidden in the tube channel as shown.

The installation – Field Adjustable Sections

FIELD ADJUSTABLE SECTIONS CAN ONLY BE CUT TO SIZE ONCE. Do not attempt to re-cut a section that has been adjusted previously. Only Field Adjustable Sections can be cut to size. Standard sections are **NOT** adjustable. Do not attempt to cut a Hi-Lite™ 30 Field Adjustable Section in wet weather. No warranty is provided on water damaged Field Adjustable Sections.

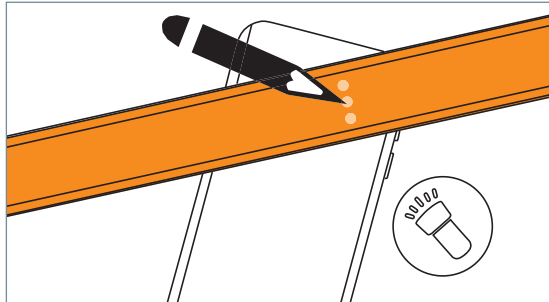

1. Field Adjustable Hi-Lite™ 30 tubes can be cut at specific locations approximately every 50mm (2"). To locate a cut position shine a torch (or smart phone with torch function) from the face side. Cut positions will be seen as a row of three bright dots along the rear of the tube. Mark the required cut position.

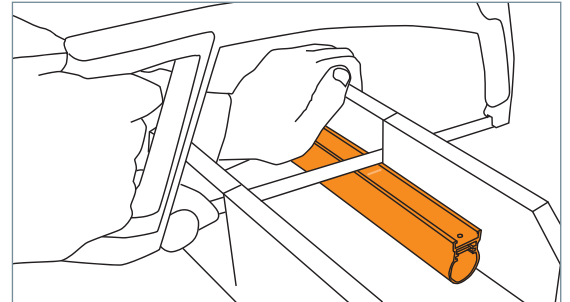

2. Field Adjustable sections must be cut from the connector end only. The portion cut off without a connector is scrap and cannot be used. Cut through the Hi-Lite™ 30 section at your mark using a hacksaw fitted with a fine-toothed blade. Use a mitre box to ensure a clean, square cut.

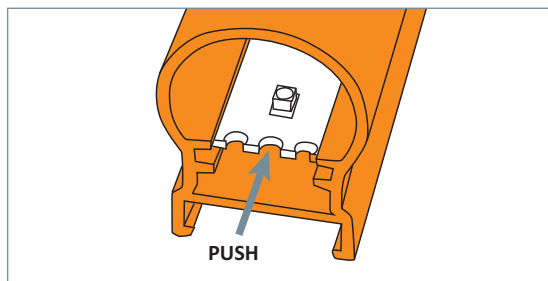

3. Remove any burrs and foreign material from the cut end. Ensure the cut is clean and square (sand if necessary). The end-cap will not form a weatherproof seal to an uneven face. Before fitting the field end-cap, push the cut circuit board into the tube as far as it will go.

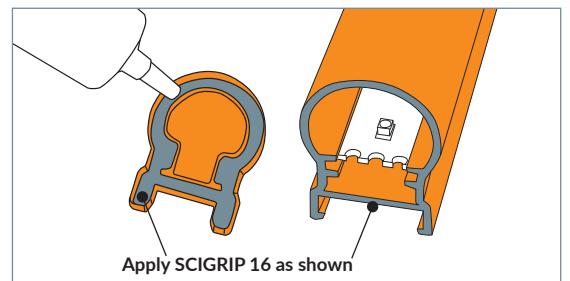

4. Apply a generous, continuous bead of **SCIGRIP 16** to both the end-cap and the cut end of the Hi-Lite™ 30 section. Do not substitute any alternative adhesive or sealant. Use **SCIGRIP 16** in a well ventilated area, following the safety instructions on the tube.

5. With the tube section held vertically, use strong tape to hold the end-cap in position. Wait for **at least 15mins** before handling the tube further or moving it from the vertical position. The section can be fitted after 30mins.

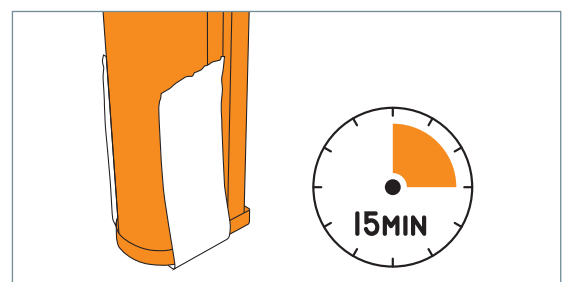

The installation – Current Sense Circuit (CSC) operation

The Current Sense Circuit (CSC) is an integral part of the PSU. Its function is to continuously monitor the installation and remove the low-voltage supply should a fault be detected. Whilst it is primarily a safety feature, it can also assist in troubleshooting.

The CSC has a status LED which indicates the current state of the circuit. On the standard 240W supply there is an LED for each output channel. The CSC is a sophisticated electronic device which takes a number of complex measurements from the system in order to recognise fault conditions.

It is not necessary to understand the detailed functions of the operation algorithms in order to successfully install or troubleshoot a Hi-Lite™ installation, however a description of the CSC and its operation is set out below for information.

Operation

During normal operation the CSC continuously and automatically performs tests on the DC supply to the Hi-Lite™ installation. Should a fault be detected the DC output is switched off. Once this has occurred, a series of attempts to reinstate the DC supply are made at intervals increasing from 1 second to 1 hour.

Should any re-try be successful, the DC output is switched on and the CSC enters a back-off mode. Whilst in this back-off mode the re-try period that will be applied, should a further fault be detected, is slowly reduced back to 1 second.

Should the fault still be present after the full retry cycle (around 5 hours), the CSC enters an abort mode. Once in this mode, no further retries are made and the status LED flashes red.

When a fault is detected, the status LED pulses a number of times rates to indicate the type of fault. The table below lists these faults.

Pulse ratio	Fault indicated
2 pulses	Start-up impedance test failure
3 pulses	Current monitor failure
4 pulses	Run-time impedance test failure
5 pulses	Reserved
6 pulses	Run-time voltage test failure
7 pulses	Start-up voltage test failure
8 pulses	Over-current

Possible causes for each fault type are:

2 pulses: Start-up impedance test failure

The system has detected a low resistance across the output before it has applied power. This can be caused by a faulty or damaged tube section, badly made connections between sections or water inside the connectors.

3 pulses: Current monitoring failure

The system has detected fluctuations in current in the installation. This is usually caused by a faulty or damaged tube section or a badly made connection between sections.

4 pulses: Run-time impedance test failure

Similar to 2 pulses, but this test is carried out at 10 second intervals during normal operation.

6 pulses: Run-time voltage test failure

This test is carried out at 10 second intervals during normal operation and a failure indicates either a faulty or damaged tube section (usually with water ingress, or the connectors contain trapped water).

7 pulses: Start-up voltage test failure

Similar to 6 pulses, but this test is carried out at start-up, before power is applied.

8 pulses: Over-current failure

The load exceeds the maximum allowed. Reduce the load on the output channel.





Should the mains input to the PSU be cycled once the CSC is in the abort mode, the CSC first attempts a power-up. If this is successful, normal operation resumes and the CSC enters its continuous monitoring mode once again.

The installation – PSU loadings

All IP-rated power supply units feature twin outputs. On 20W, 40W and 96W supplies, these outputs are internally connected in parallel so Hi-Lite™ 30 sections can be connected in any combination.

For example, all the sections can be connected to only one output, or they can be split in any combination across the outputs.

240W power supplies feature two independent outputs, each capable of delivering up to 120W. If any power supply outputs are not used, be sure to fit a blanking plug to the unused connector.

Power supply	Total output power	Hi-Lite™ 30 green (HL3-xx-G5)	All other colour codes
 <p>PS-S-20</p>	20W	18m (59'1") total in any configuration across the two outputs	4m (13'1½") total in any configuration across the two outputs
 <p>PS-S-40</p>	40W	36m (118'3") total in any configuration across the two outputs	8m (26'3") total in any configuration across the two outputs
 <p>PS-S-96</p>	96W	43m (141'1") max on each output, 86m (282'2") total	19m (62'4") total in any configuration across the two outputs
 <p>PS-S-240</p>	2 x 240W	N/A	24m (78'9") max. on each output, 48m (157'5¾") total



VISIVE®

POWERED BY SMART TECHNOLOGY

UK Office

Visive Group Ltd
Ash Road South,
Wrexham Industrial Estate,
Wrexham, UK
LL13 9UG
T: +44 (0)1978 660181
Email: info@visivegroup.com

China Office

Visive Group (Guangzhou)
Commercial Lighting Co. Ltd.
Rm. 1707, Tianyin Bldg.,
437 Zhongshan Avenue,
Tianhe Guangzhou,
China, 510660
T: +86 20 2383 6842
Contact: Andy Zheng - Director
Email: za@auxisolution.com

Distributor

Bever Innovations B.V.
Industrieweg 32,
4301 RS Zierikzee,
The Netherlands
T: +31 (0)111 453 232
Email: info@beverinnovations.com

Distributor

dk LED
Ekkersrijt 1209,
5692 AG Son en Breugel,
The Netherlands
T: +31 499 476 777
Email: info@dkled.nl

USA Stockist

Wired4Signs USA, LLC.
7669 Clinton Highway
Powell, TN 37849, USA
T: +1 (865) 339 4956
www.wired4signsusa.com

www.visivegroup.com

